

Conveyor trolley roller lubrication

GIS system for grease lubrication of trolleys and carriage rollers on monorail forged-chain conveyors

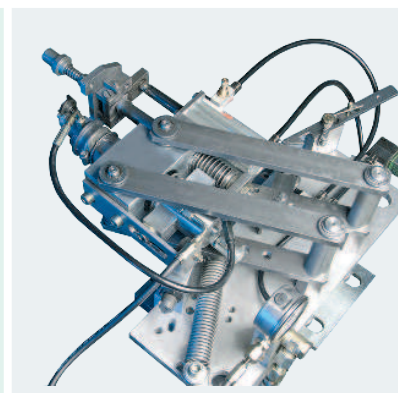
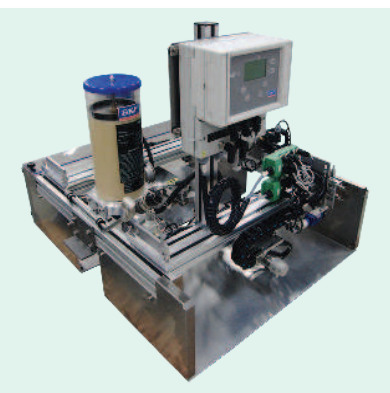
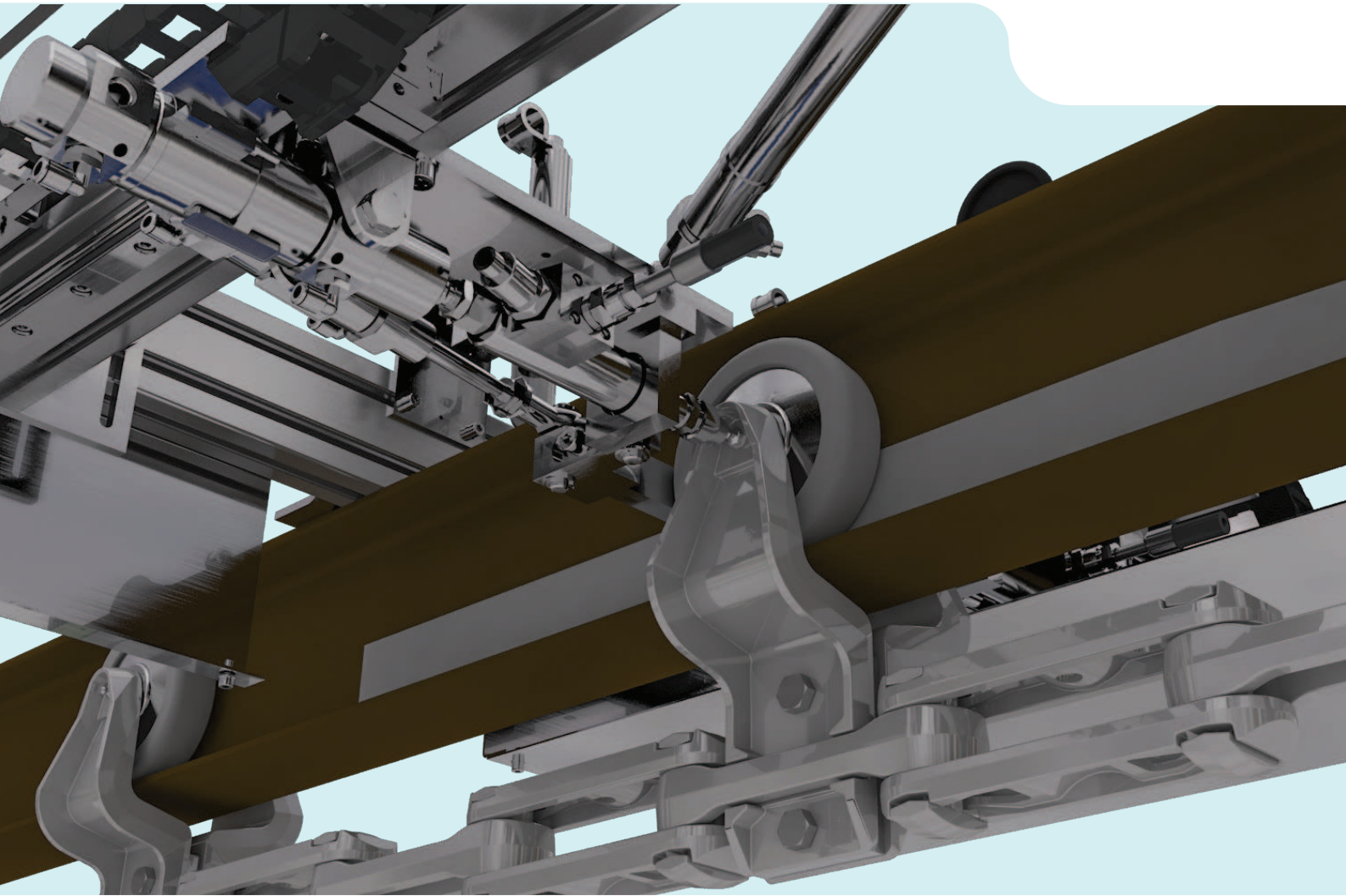

GIS system

Description

For monorail forged-chain conveyors, the GIS (Grease Injection System) lubrication system injects grease inside the trolley rollers through the original greaser while the conveyor is running.

GIS systems adapt the various conveyor configurations and applications: chain trolley roller greasing or carriage roller greasing (power and free conveyor).

GIS systems for trolley rollers enable simultaneous lubrication of two rollers or several carriage rollers.

Applications

- Automotive industry
 - Welding line
 - Surface treatment line
 - Paint line
 - Assembly line
- Food and beverage industry
 - Transport of carcasses
- General industry
 - Surface treatment line
 - Paint line

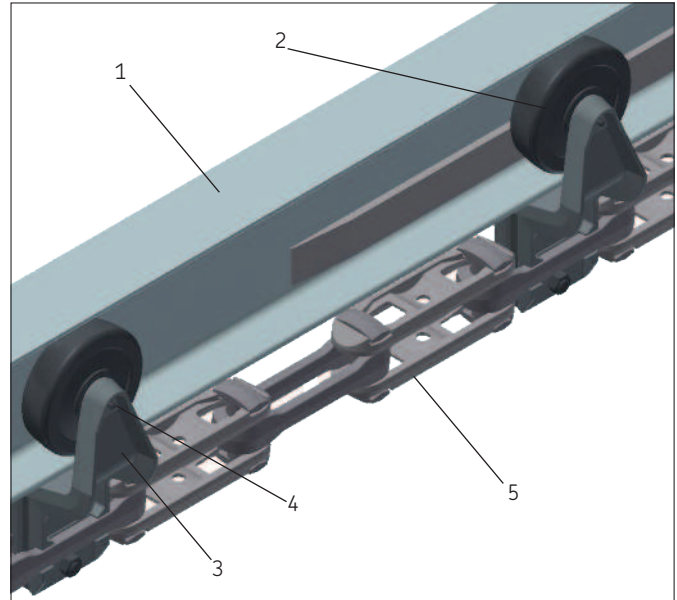

Monorail forged-chain conveyor

- 1 Guide rail
- 2 Trolley roller
- 3 Trolley
- 4 Grease nipple
- 5 Forged-chain

Operation principle

The GIS lubrication system only works when the conveyor is running.

During the lubrication phase, when the roller passes in front of the unit, the pick-up system is triggered to let the injection head couple mechanically with the roller. It follows the chain motion while injecting the correct quantity of grease.

At the end of the injection cycle, the head and pick-up system move backwards. The unit returns to its initial position and is ready for a new injection cycle on the next roller.

Customized solutions

Each industrial conveyor chain is specific due to its design, field of application, conditions of use, etc.

The SKF teams have thorough knowledge of the fields of application, combined with numerous years of experience. Many GIS systems are already in service in various industrial sectors throughout the world and have proven their worth.

As a result, SKF teams are capable of satisfying various requests, either by modifying an existing solution or by developing a completely new system. Therefore, the lubrication solution proposed is therefore perfectly adapted to the customer's needs and unique requirements.

This brochure provides a general description of the GIS lubrication system. Please contact SKF for more detailed information.

One system, two lubrication units

SKF offers two different lubrication units for lubrication of trolley rollers: COBRA and GVP

COBRA

GIS system with COBRA unit is the simple solution for lubrication of chain trolley rollers, in particular in heavy industry and harsh environment. The movements required for the injection cycle are mechanically and pneumatically driven. With the standard system version activation is manual. But some versions with electrically automated activation are available. It is also possible to add several monitoring functions.

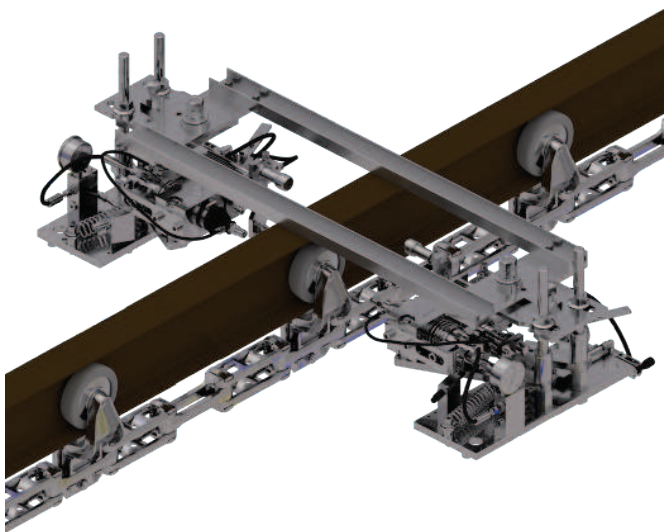

COBRA unit

- Sturdy design
- Manual activation
- System automation in option
- Possibility to add monitoring functions
- Easy installation
- Easy to use
- Pneumatic system
- Volumetric metering

GVP

GIS system with GVP unit is the advanced solution for the lubrication of chain trolley rollers or carriage rollers. This solution manages and controls lubrication cycles automatically.

GIS system adapts to a broad range of chain speeds as well as various conveyor configurations and roller positions.

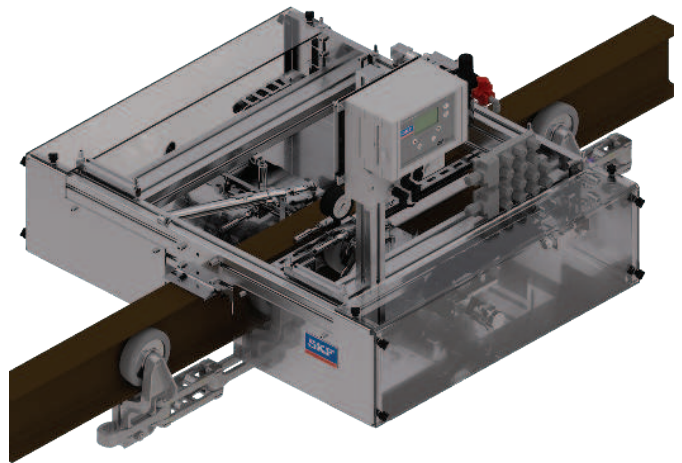

GVP unit

- Fully automated system
- Configurable control of lubrication cycles
- Injection frequency adaptable to chain speed
- Operation check
- Failure notification
- Electropneumatic system
- Volumetric metering

GIS system with COBRA unit

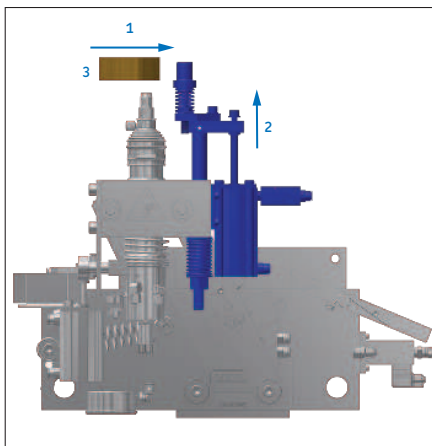
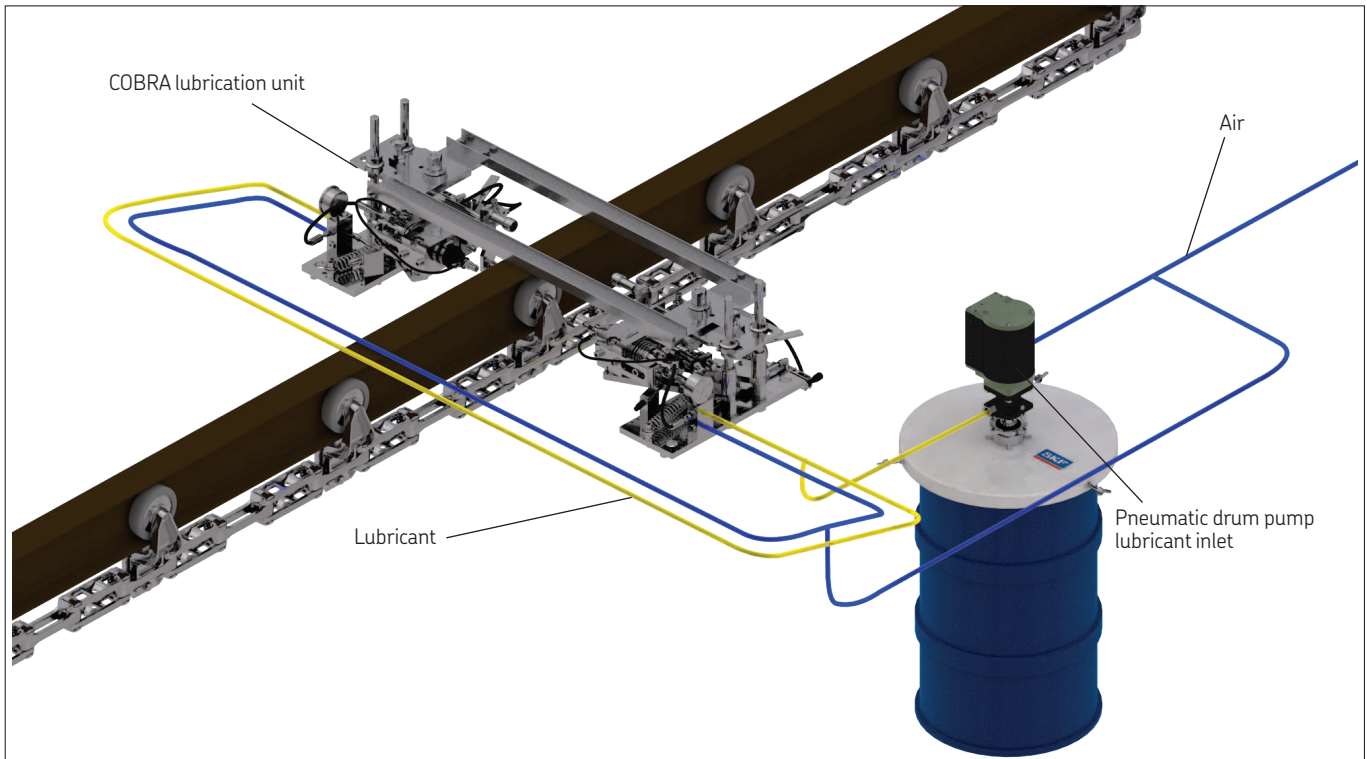

Coupling

- Lubrication point in front of the COBRA unit
- Pick-up cylinder extension with fingers

- 1 Chain movement direction
- 2 Pick-up finger movement
- 3 Roller

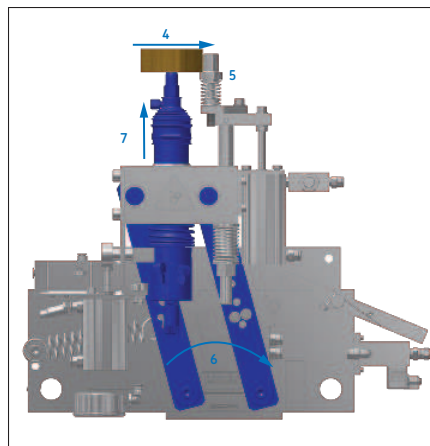

Injection

- Pick-up fingers in contact with roller
- Oscillating arms swivel, driven the roller
- Injection head comes into contact with roller grease nipple
- Grease injection into roller

- 4 Chain movement direction
- 5 Pick-up fingers blocked against roller
- 6 Oscillating arms swivel
- 7 Injection head moves towards roller grease nipple

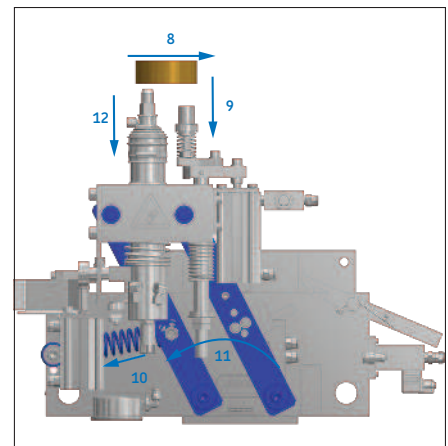

Return

- Metered quantity of grease injected into roller
- Injection head removed from roller
- Pick-up fingers retract
- Oscillating arms return to initial positions under return spring force

- 8 Chain movement direction
- 9 Retraction of pick-up fingers
- 10 Spring traction direction
- 11 Oscillating arms swivel
- 12 Withdrawal of injection head

GIS system with GVP unit

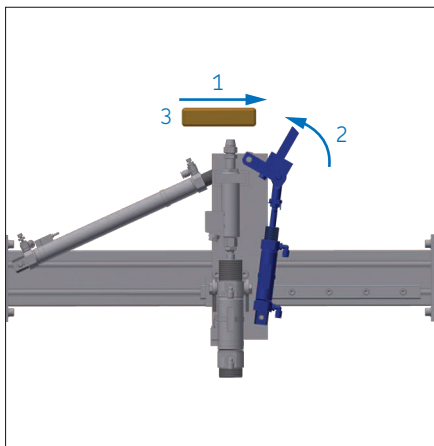
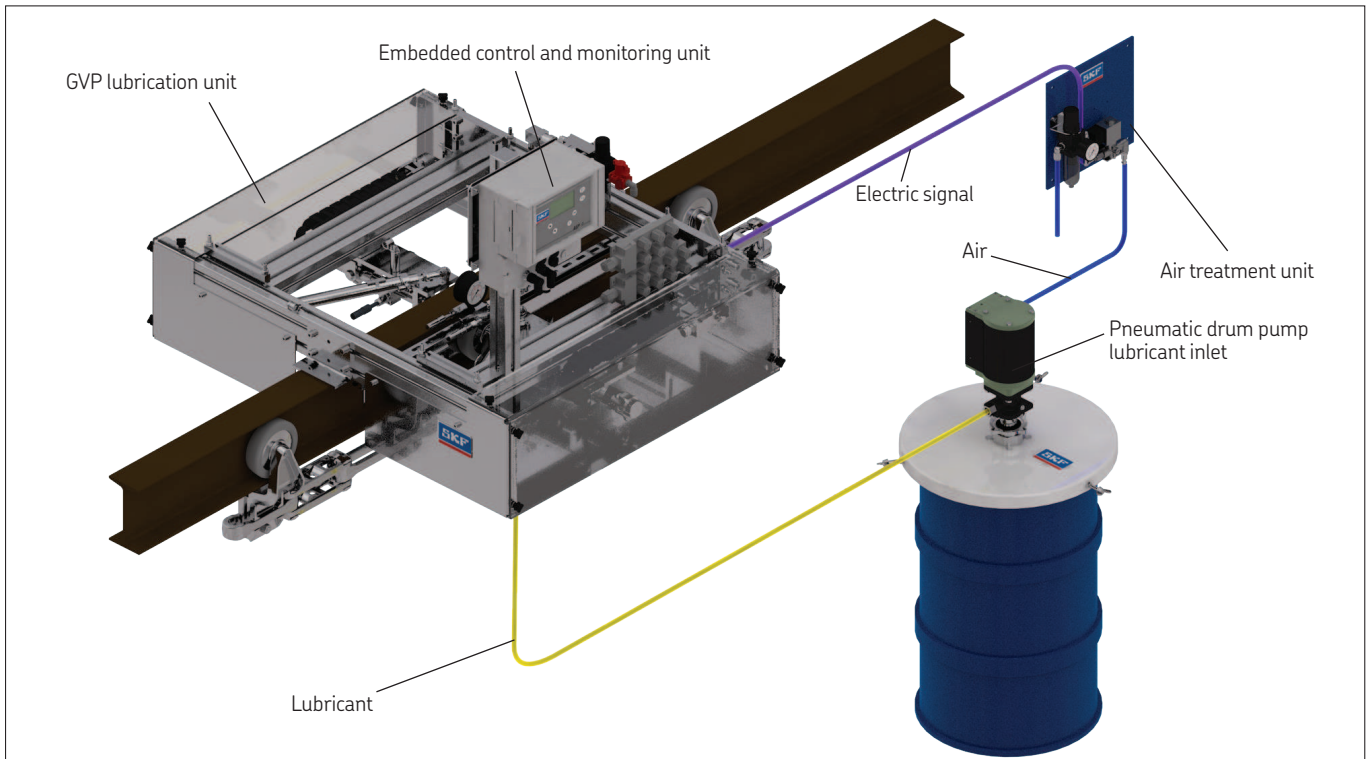

Coupling

- Lubrication point in front of GVP unit
- Pick-up cylinder extends and pick-up fingers swivel

- 1 Chain movement direction
- 2 Pick-up finger movement
- 3 Roller

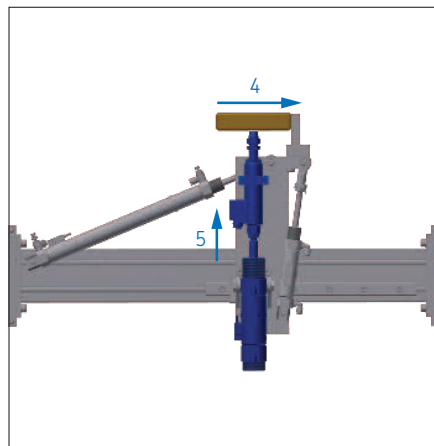

Injection

- Pick-up fingers in contact with roller
- Injection carriage moves in parallel with the chain, driven by the roller
- Injection cylinder extension
- Injection head comes into contact with roller grease nipple
- Grease injection into roller

- 4 Chain movement direction
- 5 Injection cylinder extension and injection head moves towards roller grease nipple

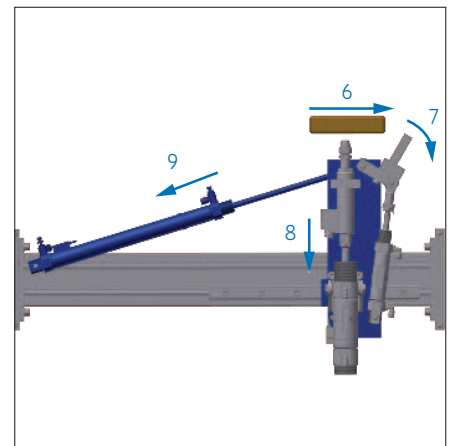

Return

- Metered quantity of grease injected into roller
- Pick-up fingers swivel and disengage the carriage from the roller
- Injector moves back
- Return cylinder pulls back injection carriage to its start position

- 6 Chain movement direction
- 7 Retraction of pick-up fingers
- 8 Injector moves back
- 9 Return cylinder movement

GIS systems technical data

	COBRA unit	GVP unit
General specifications		
Start/Stop	manual or automatic	automatic
Lubrication cycle	according to option	automatic
Time configurable	according to option	1 min to 365 d
Pulse configurable (chain laps)	according to option	1 lap to 999 laps
Volume injected	0,2 to 2 cm ³ * (factory setting 0,5 cm ³)	0,33 ; 0,5 ; 0,75 and 1 cm ³ * (factory setting 0,5 cm ³)
Max. injection frequency	1/s	1/s
Max. distance between injection head and nipple	36,5 mm	max. 20 mm
Chain position	horizontal	horizontal
Max. chain speed [m/min]	24 **	18 **
Max. variation of the chain position	± 25 mm horizontal; ± 1,5 mm vertical	± 5 mm horizontal; ± 1 mm vertical
Ambient temperature limits	5 °C to 60 °C (41 °F to 140 °F)	5 °C to 55 °C (41 °F to 131 °F)
Compressed air	5,5 to 6 bar (80 to 87 psi)	4 to 8 bar (58 to 116 psi)
Air quality	quality class 5 according to standard DIN ISO 8573-1	quality class 5 according to standard DIN ISO 8573-1
Power supply	according to option	115 / 230 V AC
Operating checks		
Pneumatic supply pressure	according to option	yes
Grease supply pressure	according to option	yes
Chain displacement during the lubrication phase	according to option	yes
Carriage departure/return	according to option	yes
Injector departure/return	according to option	yes
Monitoring and display of injection pressure	no	according to option
Construction		
Main materials	steel, aluminum	steel, aluminum
Dimensions	460 × 700 × 350 mm	1 100 × 950 × 350 mm
Attachment support	not included	included
Protection cover	not included	included
Number of injection heads	1	1, 2, 3 or 4
Injection head drive	mechanical/pneumatic	pneumatic
Lubricant supply		
Grease	up to NLGI grade 2	up to NLGI grade 2
Pressure required	120 to 240 bar (1 740 to 3 480 psi)	150 to 350 bar (2 175 to 5 076 psi)
Grease flow rate required	120 cm ³ /min	60 cm ³ /min
Grease supply	external with drum pump	external with drum pump integrated with reservoir pump
Grease supply connection	G 3/8	G 3/8

*) The maximal injected volume of lubricant depends on chain speed and pitch, lubricant type, system configuration and surrounding conditions

***) The maximal admissible chain speed depends on injected volume, chain pitch, lubricant type, system configuration and surrounding conditions

NOTE

The technical specifications are as general as possible and are provided only as a guide.

Since each COBRA and GVP unit meets the specific requirements of the application, these specifications may vary.



LMC2 control unit

COBRA option

- Control of lubrication and pause phases (pulse)
- Operation check
 - hydraulic and pneumatic pressures
 - lubricant level

LMC2 main technical specifications

Operating voltage	24 V AC / 230 V DC
Current	10 A / 4 A
Protection class	IP 54
Operating temperature	-10 °C to +70 °C (10 °F to 150 °F)
Fault output	min. drum pump level chain running contact air pressure lubrication point sensor left system fault right system fault
Lubrication phase	in laps
Pause phase	in laps



AEP2 control unit

GVP standard

- Configurable control of lubrication and pause phases (time, pulse, lubrication ratio)
- Operation check
 - mechanical position
 - injection time
 - hydraulic and pneumatic pressures
 - lubricant level
- Failure history
- Multilingual

AEP2 main technical specifications

Operating voltage	24 V DC 115/230 V AC, 50/60 Hz
Current	1 A
Protection class	IP 65
Operating temperature	0 °C to 60 °C (32 °F to 140 °F)
Failure output	chain stopped air pressure lubricant pressure chain start/stop lubrication point identification trolley departure and return injector departure and return
Lubrication phase	in laps
Pause phase	in laps or time



Drum pump

COBRA and GVP

The GIS unit can be supplied with grease by an SKF transfer pump or other pump adapted for standard commercially available drums.

This pump requires the minimum technical specifications shown in the table opposite.

Drum pump specifications required

Air pressure	3 to 7 bar (53 to 66 psi)
Lubricant outlet pressure	150 to 350 bar (2 176 to 5 078 psi)
Minimum flow rate	100 g/min
Grease type	NLGI 1 and 2
Drum volume	25 kg (standard) or 50 kg according to supplier's delivery
Electrical level switch	min. (option)



Integrated pump

GVP option

The integrated supply pump results in an all-in-one lubrication system of compact size that is easy to install and use.

The pump is driven pneumatically and has one or several level checks.

The pump reservoir must be filled under pressure.

Integrated pump technical specifications

Pneumatic inlet	5 to 8 bar (72 to 116 psi)
Flow rate	3 cm ³ /stroke
Grease type	NLGI 1 and 2
Reservoir	transparent plastic
Electrical level switch	min. (standard) alert and max. (option)
Reservoir Capacity	8 or 10 kg
Material	PMMA (acrylic)



skf.com | skf.com/lubrication | lincolnindustrial.com

® SKF and Lincoln are registered trademarks of the SKF Group.

© SKF Group 2018

The contents of this publication are subject to the publisher's copyright and their reproduction, even partial, is prohibited without prior written permission. The greatest care has been taken to ensure accuracy of the information contained in this publication, however, SKF declines any responsibility for any losses or damages, direct or indirect, arising from the use of the information contained herein.

PUB LS/P2 17499 EN · June 2018